



SHF Communication Technologies AG,

Wilhelm-von-Siemens-Str. 23 D • 12277 Berlin–Marienfelde • Germany

Phone ++49 30 / 772 05 10 • Fax ++49 30 / 753 10 78

E-Mail: mail@shf.biz • Web: <http://www.shf.biz>

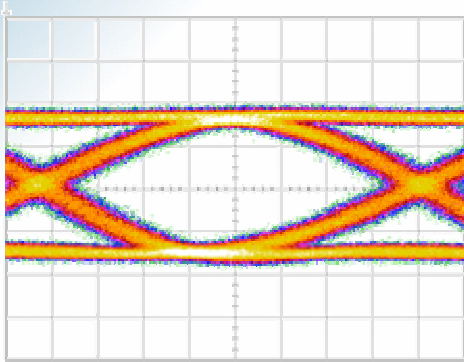

Datasheet

SHF 1120 B

Clock Recovery





Description

The SHF 11120 B is an clock recovery unit including an optical receiver.

By using an internal tap coupler, the optical input signal appears at the optical output with only minimum attenuation.

The extracted optical signal is converted by a receiver to an electrical signal which is processed by the clock recovery circuit.

The clock recovery extracts a clock signal at a frequency half of the incoming bit rate of about 40 Gbps or about 43 Gbps. It contains two separate VCOs which allow operation in a standard mode at about 39.81 Gbps (STM-256) or in an FEC mode (OUT-3) at about 43.01 Gbps. Two reference frequencies are included as standard. The clock recovery option does not support broadband operation.

Features

Optical Receiver

Optical through port with minimal attenuation

High optical sensitivity

Clock Recovery

supports multiple data rates (standard bit rate mode at OC-768, NON FEC rates around 39.8 Gbps and FEC bit rate mode at bit rates around 43 Gbps)

clock output frequency at half of the nominal input data bit rate

a reference signal at input bit rate divided by 64 is required

excellent tolerance against input signal jitter



Specifications – SHF 11120 B

Parameter	Unit	Min.	Typ.	Max.	Comment
40/43 Gbps Data Input					
Operating bit rate	Gbps				
VCO1		39.5		40.1	NON FEC mode
VCO2		42.5		43.1	FEC mode
625/672 MHz Reference Clock Input (bit rate divided by 64)					
Input Frequency	MHz	617		627	NON FEC mode
		664		674	FEC mode
Input Voltage	mV	200		800	
Half Clock Output (half bit rate)					
Output Frequency	GHz	19.75		20.05	NON FEC mode
		21.25		21.55	FEC mode
Output Voltage	mVpp	400	600	800	
RMS-Jitter	fs		500		on scope display, measured with Agilent 86100A with precision time base + 70GHz sampling head

Parameter	Specification
Optical insertion loss	
1310 nm	< 1 dB
1552 nm	< 1 dB
Optical input dynamic range	
1552 nm	+3 to -3 dBm

Precautions with optical connectors

The fiber optic connectors must be kept clean in order to ensure best performance of the SHF 11120 B. Contaminated or damaged fiber ends result in performance degradation. Cover connectors with dust caps when they are not in use.

The following cleaning procedure is recommended for the connector interface of the SHF 11120 B and the external connectors attached to these ports.

Before cleaning, the external connectors should be detached from the SHF 11120 B.

To clean the fiber-end face, use a new natural cotton swab that is moistened with isopropyl alcohol.

We recommend that no other solvents are used to clean the optical surfaces.

Move the swab back and forth across the fiber end face several times applying a gentle pressure.

Afterwards dry the fiber end face with a clean dry cotton swab or lens paper.

Do not press the swab or lens paper too hard onto the fiber end face. This may damage the surface.

Use clean dry compressed air (free of dust, water and oil) to blow away any remains from the fiber end face. Nitrogen gas can also be used.



Block diagram

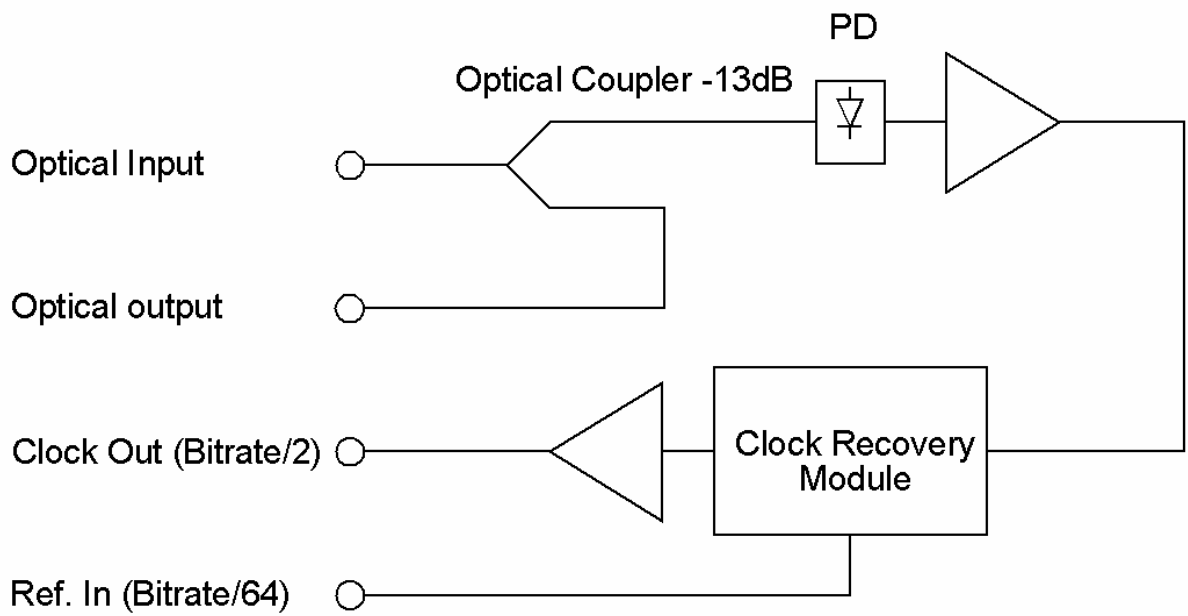



Test Results

Typical output signals at 39.81 Gbps

-3dBm Optical Input Power	+3dBm Optical Input Power
---------------------------	---------------------------

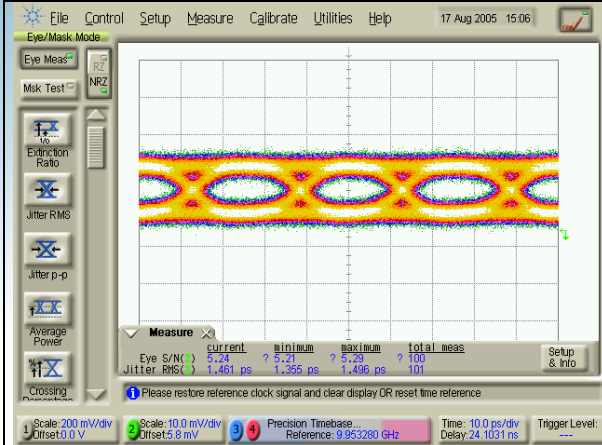

Optical Output Signal

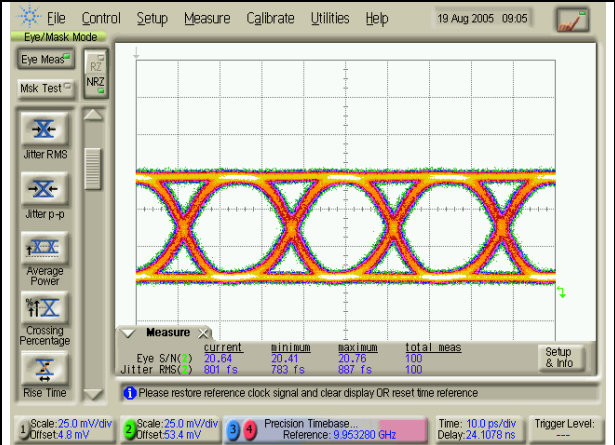

Optical Output Signal

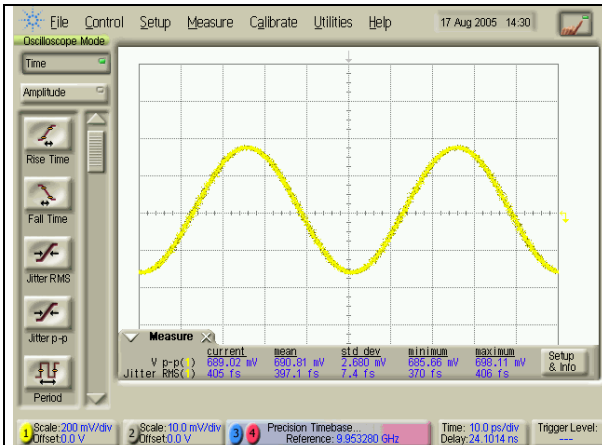

Clock Output Signal

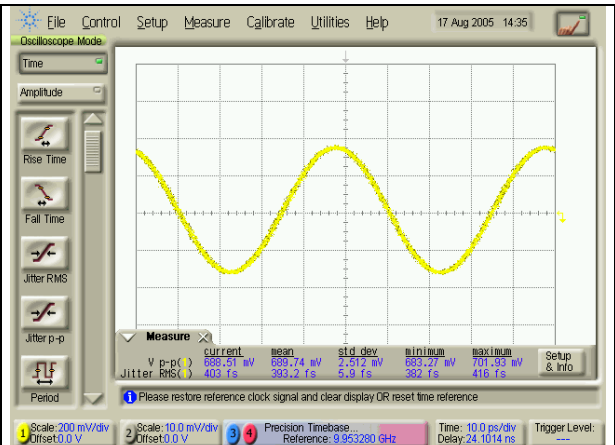

Clock Output Signal



Application Remarks Clock Recovery

1. The Clock Recovery Module is controlled by two push buttons on the left hand side of the front panel.

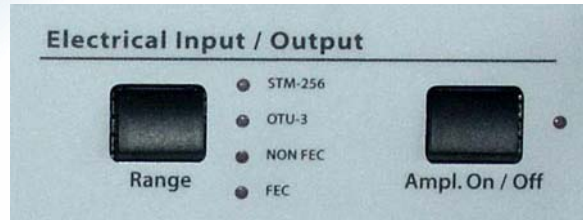

2. The internally used phase detector needs a bit rate divided by 64 reference signal. If the operating bit rate deviates from those supported by the internal reference oscillators (STM-256, OTU-3), an external reference signal has to be applied, e.g. operation at exactly 40 Gbps requires a 625 MHz reference signal (40G/64). If an operating mode using an external reference is selected it is indicated by a red LED next to this reference clock input "Ref. In (Bitrate/64)".
3. If the "STM-256" (39.813 Gbps) or the "OTU-3" (43.018 Gbps) mode is selected and internal oscillator is used for the reference signal.
4. The unit can be operated in two bit rate ranges – the "NON FEC" range between 39.5 Gbps and 40.1 Gbps and the "FEC" range between 42.5 Gbps and 43.1 Gbps. The appropriate operating range has to be selected using the "Range" button. An external reference clock of frequency bit rate divided by 64 is required.



Operation at 39.81 Gbps (STM-256)

Set the unit to "STM-256" using the "Range" button.

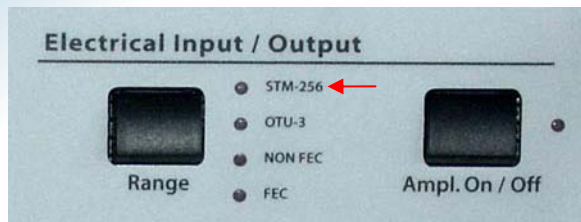

Apply a 39.81 Gbps data signal to the optical input.
Turn on the output amplifier using the "Ampl. On/Off" button.
The recovered 19.9 GHz clock signal is available at the "Clock Out (Bitrate/2)" output.

Operation at 43.01 Gbps (OTU-3)

Set the unit to "OTU-3" using the "Range" button.

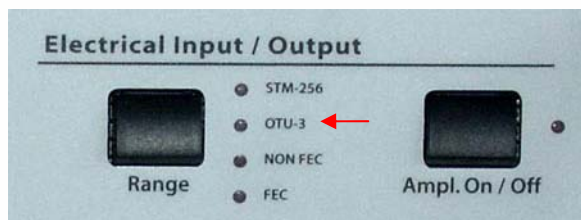

Apply a 43.01 Gbps data signal to the optical input.
Turn on the output amplifier using the "Ampl. On/Off" button.
The recovered 21.5 GHz clock signal is available at the "Clock Out (Bitrate/2)" output.

Operation between 39.5 Gbps and 40.1 Gbps

Set the unit to "NON FEC" using the "Range" button.

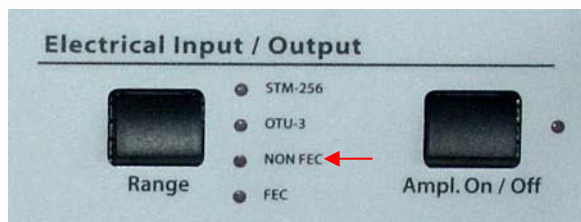

Apply a reference clock signal (bit rate divided by 64) to the "Ref. In (Bitrate/64)" input.
Apply a data signal to the optical input.
The recovered clock signal is available at the "Clock Out (Bitrate/2)" output.

Operation between 42.5 Gbps and 43.1 Gbps

Set the unit to "FEC" using the "Range" button.

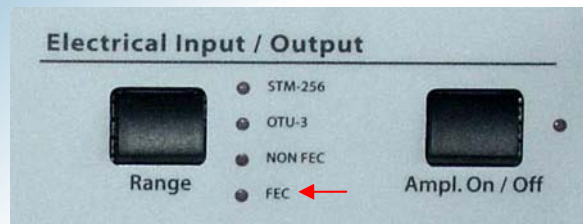

Apply a reference clock signal (bit rate divided by 64) to the “Ref. In (Bitrate/64)” input.
Apply a data signal to the optical input.
The recovered clock signal is available at the “Clock Out (Bitrate/2)” output.