



SHF Communication Technologies AG

Wilhelm-von-Siemens-Str. 23D • 12277 Berlin • Germany

Phone ++49 30 / 772 05 10 • Fax ++49 30 / 753 10 78

E-Mail: sales@shf.de • Web: <http://www.shf.de>

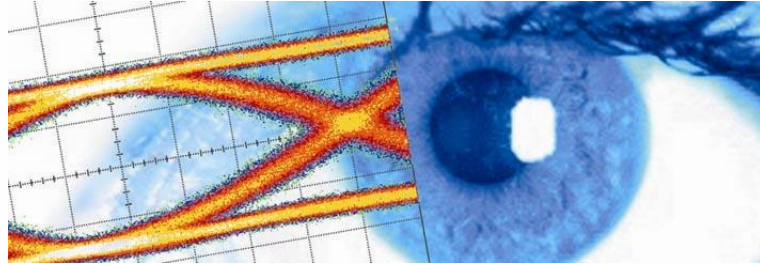

Datasheet

SHF 46213 D

Optical QAM Transmitter



Description

The SHF 46213 D is an optical QAM transmitter unit. It is a field replaceable plug-in module which needs to be installed in a mainframe type SHF 10001 A/B or SHF 10000 A/B/C Together with other plug-in modules from this instruments series, a modular and scalable measurement system can be put together.

In a QAM (Quadrature Amplitude Modulation) transmission system, the data is transmitted in the optical phase and amplitude change between the symbols. Since one transmitted symbol includes the information of n bits the symbol rate is reduced by the factor 1/n. Therefore one advantage of a QAM transmission system is a high spectral efficiency.

The SHF 46213 D uses a parallel modulator which converts 2 electrical data streams (I and Q) of up to 32 GSymbols/s into 1 optical data stream of up to 32 GSymbols/s.

If the input data streams consist of binary signals, the optical output format will be DQPSK. Multilevel input data streams will generate the PAM/QAM modulation.

Both electrical data streams modulate the light by a thermally stable Chirp-free Lithium Niobate Mach-Zehnder modulator with a phase difference of $\pi/2$. Before superposition of the two light streams the Q part gets $\pi/2$ shifted in order to have four different phase states in the transmitted signal.

The 2 data channels can be switched On and Off independently, thus permitting to generate either DPSK or DQPSK signals.

To detect and to demodulate either the I or the Q channel, the 28 Gbps DPSK optical receiver SHF 47215 A is the ideal instrument. It is possible to switch between the I and the Q channel for eye analysis or BER measurement of both channels separately.

For a 32 Gbps DQPSK BER measurement the SHF Bit Pattern Generators (SHF 12103 A /SHF 12104 A) can provide the pre-coded I and Q data streams.

For the RZ modes, an amplified clock signal drives a third modulator. The output from this modulator is a train of pulses of constant width. For the NRZ-QAM modes, the third modulator is biased to allow light through continuously.

The temperature stable modulators and an automatic bias circuit for both the QAM and pulse carver modulators ensure high stability of the output signal.

Features

- 32 GSymbol/s optical data streams
- Separate analysis of I and Q channel possible
- Quick optimization of optical eye diagram performance by user adjustable modulator bias control
- All features are computer controlled via Bert Control Center software
- All modulators' bias conditions controlled automatically
- Selectable automatic and manual bias control (ABC circuit)



Functional block diagram

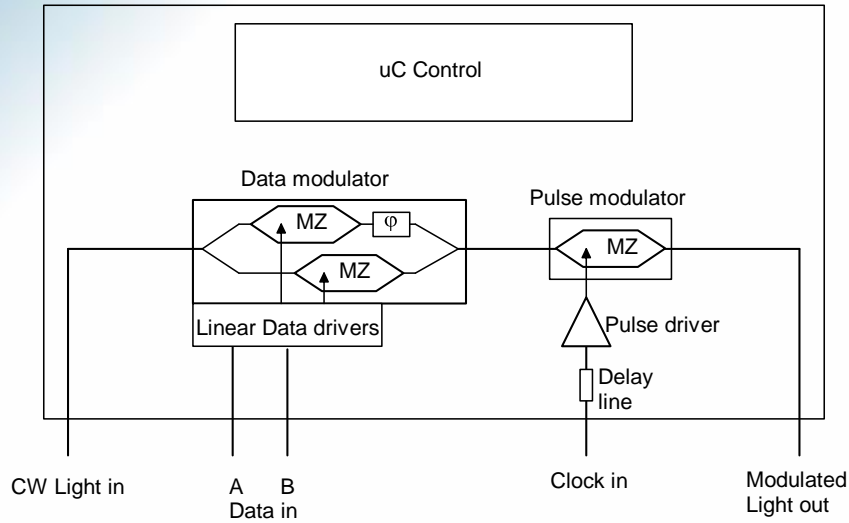

Specifications – SHF 46213D

| Parameter | Unit | Min. | Typ. | Max. | Comment |
|--|----------|---------------|------|------|---|
| Optical parameters | | | | | |
| Wavelength range | | C- and L-band | | | |
| Insertion loss | dB | | 12 | 17 | connector to connector, maximum transmission without modulation |
| DC Extinction ratio | dB | 20 | | | |
| Return loss | dB | 30 | | | |
| Electrical and electro-optical parameters | | | | | |
| Electro-optical bandwidth of Data modulator | GHz | 25 | | | -3dB optical |
| Symbol rate | Gsym/s | | | | |
| RZ-QAM | | 20 | | 32 | |
| QAM | | 5 | | 32 | |
| Drive amplifier electrical return loss | dB | | | | |
| Data | | | | -10 | |
| Clock pulse RZ | | | | -10 | |
| Data input level | V_{DD} | | | | |
| QAM (linear operation) | | | | 0.25 | |
| QPSK (binary signals, limiting) | | 0.4 | | 0.9 | |
| Clock input level (for RZ generation) | V_{pp} | 0.5 | | 1.2 | |
| Dynamic signal to noise ratio | | | | | |
| DPSK-mode, either Data A or B | | 12 | 15 | | measured with SHF 47215 A DPSK-receiver. @ 28Gbps |



Absolute maximum ratings

| Parameter | Unit | Min. | Typ. | Max. | Conditions |
|--------------------------------|------|------|------|------|------------|
| Optical input power | dBm | | | 16 | |
| NRZ data amplifier input power | dBm | | | 4 | NRZ data |
| RZ clock driver input power | dBm | | | 5.5 | CW |

General specifications

| Parameter | Unit | Min. | Typ. | Max. | Conditions |
|----------------------------------|------|------|------------|------|-----------------------------|
| Weight | kg | | 3.3 | | |
| Dimensions | mm | | 59x213x450 | | w/o Frontpanel - Connectors |
| Power consumption | W | | 20.5 | | |
| Operating temperature | °C | 10 | | 35 | |
| Electrical data input connectors | | | | | male K (2.92mm) |
| Clock input connector | | | | | male K (2.92mm) |
| Optical connectors | | | | | FC/PC ¹ |

¹ Other connectors available on request.



Test Measurements

Typical Measurement results

The following equipment was used in obtaining these results:

SHF 12103 A Pattern Generator at 28 Gbps, PRBS 2³¹-1

SHF 1550DFB Laser source set to 15mW output power @ 1550 nm.

AMPAQ EDFA + bandpass filter

Data input levels: 500 mV

Agilent 86100A DCA with 70GHz plugin and precision time base module

D(Q)PSK signals detected with SHF 47215 A 28 Gbps DPSK receiver

